

INNOVATION LEADS TO VALUE



SUNWARD

SL06W WHEEL LOADER

◆ Rated power/speed: 18.2 kW / 2 400rpm

◆ Standard bucket capacity: 0.26 m³

◆ Rated load capacity : 600 kg



CONFIGURATION

Canopy

Electric Work Control

0.26 (Detachable Shovel Teeth)

Floating Function

Quick Hitch

Triple Mechanical Operation

Pressure Measuring Valve

OPTIONAL

Rops & Fops Cabin With Maintenance Port

Log Grasper

Goods Grasper

Heater

Cold Start Device

Radio

Mp3

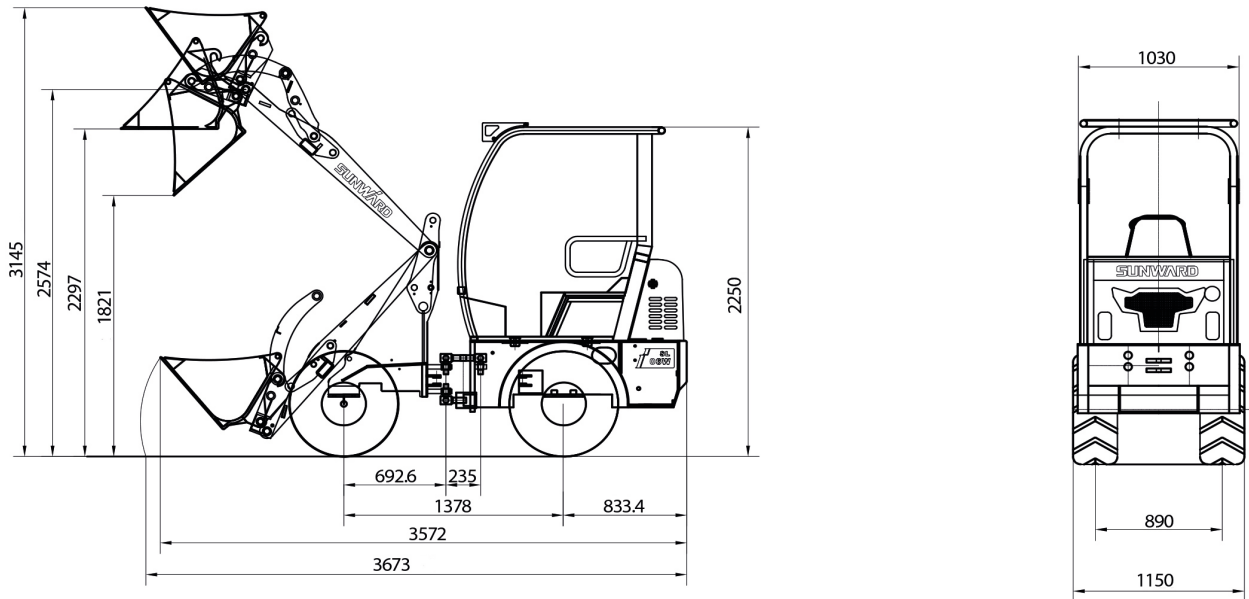

Vehicle parameters

Overall Length (bucket on ground)	3 669 mm
Overall Width	1 120 mm
Overall Height	2 310 mm
Bucket capacity	0.26 m ³
Rated load	600 kg
Overall Weight	1 700 kg
Max. Breakout Force	13 kN
Max. Tractive Force	16.7 kN
Max. Dumping height	1 830 mm
Max. Dumping reach	800 mm
Min. ground clearance	220 mm
Wheelbase	1 492 mm
Wheel tread	830 mm
Tyre	26*12.12

Engine

Manufacturer/model	KUBOTA D1105 (Euro5/EPA4)
Rated Power	18.2 kW
Rated Speed	2 400 rpm

Transmission System

Type	Hydrostatic
Shift gear control Type	Electric, Stepless
Travel speed	12 km/h

Bucket

Bucket width	1 200 mm
Bucket type	Heavy-duty bolt on teeth

Operating System

Steering system	Full Hydraulic
Min. turning radius	2 466 mm
Driving system	Hydrostatic driving, 4WD

Brake System

Service Brake	Hydrostatic brake
Parking Brake	Drum brake

