

INNOVATION LEADS TO VALUE



SL 12W WHEEL LOADER

◆ Rated power/speed: 18.5 kW / 2 200 rpm

◆ Standard bucket capacity: 0.38 m³

◆ Rated load capacity : 1 300 kg



CONFIGURATION

Canopy

Electric Work Control

0.38 (Detachable Shovel Teeth)

Floating Function

Quick Hitch

Triple Mechanical Operation

Pressure Measuring Valve

OPTIONAL

Rops & Fops Cabin With Maintenance Port

Log Grasper

Goods Grasper

Cooling Air Conditioner (Optional With Cabin)

Heater

Cold Start Device

Radio

Mp3

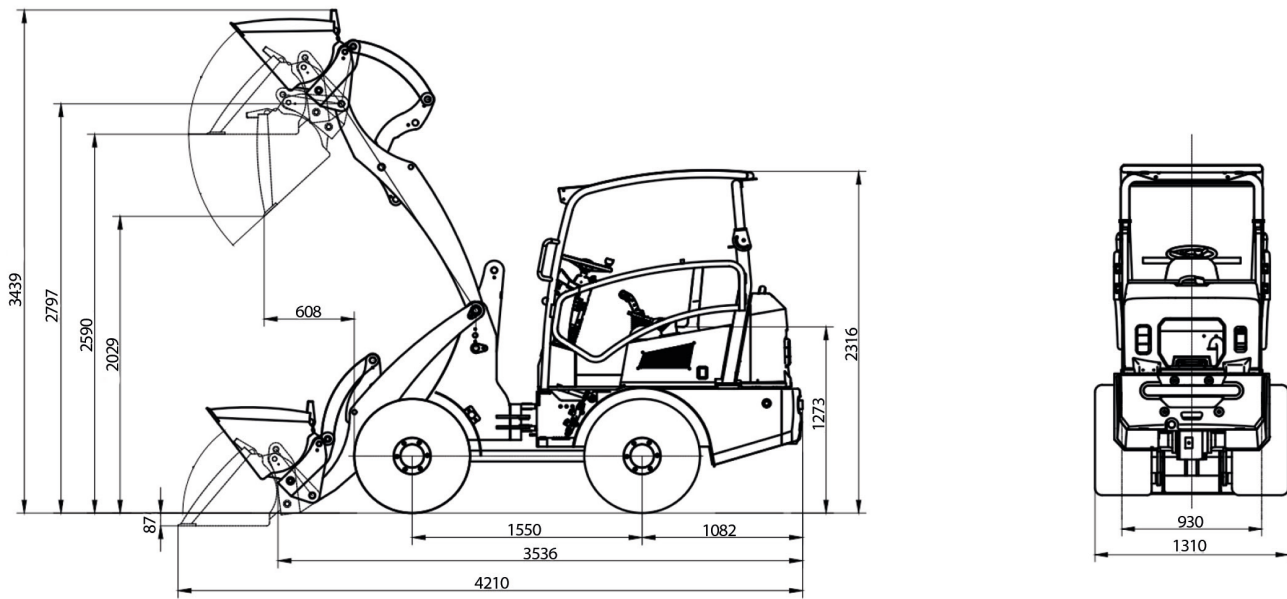

Vehicle parameters

Overall Length (bucket on ground)	4 210 mm
Overall Width	1 350 mm
Overall Height	2 336 mm
Bucket capacity	0.38 m ³
Rated load	1 300 kg
Overall Weight	2 500 kg
Max. Breakout Force	19 kN
Max. Tractive Force	17 kN
Max. Dumping height	2 029 mm
Max. Dumping reach	608 mm
Min. base to the ground	240 mm
Wheelbase	1 550 mm
WheelTread	975 mm
Tyre	10-16.5

Engine

Manufacturer/model	KUBOTA D1703 (Euro5/EPA4)
Rated Power	18.5 kW
Rated Speed	2 200 t/min

Transmission System

Type	Hydrostatic
Shift gear control Type	Electric, Stepless
Travel speed	7/18 km/h

Bucket

Bucket width	1 500 mm
Bucket type	Heavy-duty bolt on teeth

Operating System

Steering system	Full Hydraulic
Min. turning radius	3 336 mm
Driving system	Hydrostatic driving, 4WD

Brake System

Service Brake	Drum brake
Parking Brake	Drum brake

