

INNOVATION LEADS TO VALUE



# SL06W WHEEL LOADER

◆ Rated power/speed:18.2kW/2200rpm ◆ Standard bucket capacity:0.26m<sup>3</sup> ◆ Rated load capacity:600kg



## CONFIGURATION

Canopy

Electric Work Control

0.26(Detachable Shovel Teeth)

Floating Function

Quick Hitch

Triple Mechanical Operation

Pressure Measuring Valve

## OPTIONAL

Rops & Fops Cabin With Maintenance Port

Log Grasper

Goods Grasper

Heater

Cold Start Device

Radio

Mp3

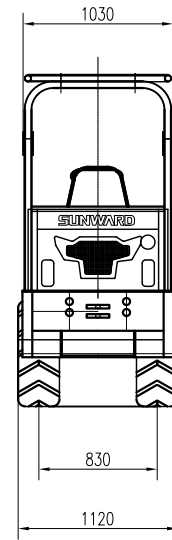
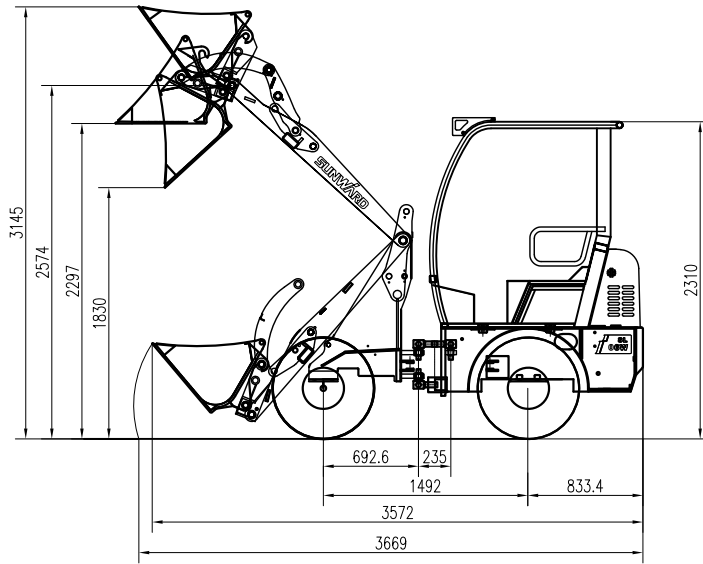

Vehicle parameters	
Overall length (bucket on ground)	3669mm
Overall Width	1120 mm
Overall Height	2310 mm
Bucket capacity	0.26 m <sup>3</sup>
Rated load	600 kg
Overall Weight	1700 kg
Max.Breakout Force	13.0 kN
Max.Tractive Force	16.7 kN
Max.Dumping height	1830 mm
Max.Dumping reach	800 mm
Min.base to the ground	220 mm
Wheelbase	1492 mm
WheelTread	830 mm
Tyre	26*12.12

Engine	
Manufacturer/model	KUBOTA D1703 (Euro5/EPA4)
Rated Power	18.5 kw
Rated Speed	2200 r/min

Transmission System	
Type	Hydrostatic
Shift gear control Type	Electric, Stepless
Travel speed	12

Bucket	
Bucket width	1200
Bucket type	Heavy-duty bolt on teeth

Operating System	
Steering system	Full Hydraulic
Min.turning radius	2466
Driving system	Hydrostatic driving, 4WD

Brake System	
Service Brake	Hydrostatic brake
Parking Brake	drum brake

