

SWSL0807AC-A

SWSL Fully Electric Scissor lifts



Standard Functions

Proportional control	Unidirectional extension platform	Folding fence	Platform self-locking door
Airless tires without imprint	Timer	Standard transport forklift holes	Safe maintenance support rods
Horn	Flash lamp	Motion buzzer	DC motor driven/Hydraulic pump driven
Pit protector	Emergency descending system	Emergency stop system	Automatic braking system
Tilting protection system	Charging protection system	Fault diagnosis system	

Optional Functions

Air pipe to platform	AC power source connected to platform	GPS tracking system	Overload protection system
Maintenance-free battery	Lithium battery and management system	Intelligent interconnection system	Platform work lights

TECHNICAL PARAMETERS



SWSL0807AC-A

Dimension

	Maximum working height	7.8m
A	Maximum platform height	5.8m
B	Height of retracted platform	1.05m
C	Length of working platform	1.7m
	Extension dimension of platform	0.9m
D	Width of working platform	0.74m
E	Height - retracted (guardrail raised)	2.17m
	Height - retracted (guardrail folded)	1.79m
F	Overall length	1.86m
G	Overall width	0.76m
H	Wheel base	1.38m
I	Ground clearance (retracted state)	0.083m
J	Ground clearance (extended state)	0.02m

Performance

Rated load	230Kg
Safe working load of extended platform	113Kg
Maximum number of workers	2
Travel speed (retracted state)	4.0Km/h
Travel speed (extended state)	0.8Km/h
Ascending/descending speed	18s/25s
Maximum gradeability**	25%
Maximum allowed working angle	1.5°/3°
Drive	Two front wheels
Multi-disc brake	Two front wheels
Tire - airless without imprint(outer diameterxwidth)	323mmx100mm
Battery	4x6V/200Ah
Charger	24V/30A
Weight	1520Kg

* The working height equals to the platform height plus 2 m.

** The gradeability is adaptive to driving on slopes; refer to the Operation Manual for relevant levels of gradeability.

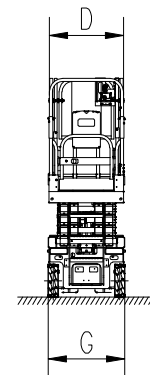
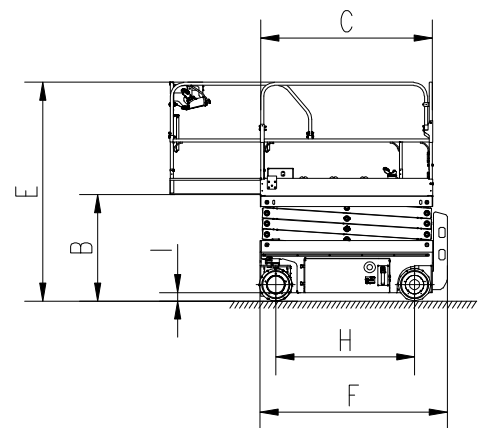
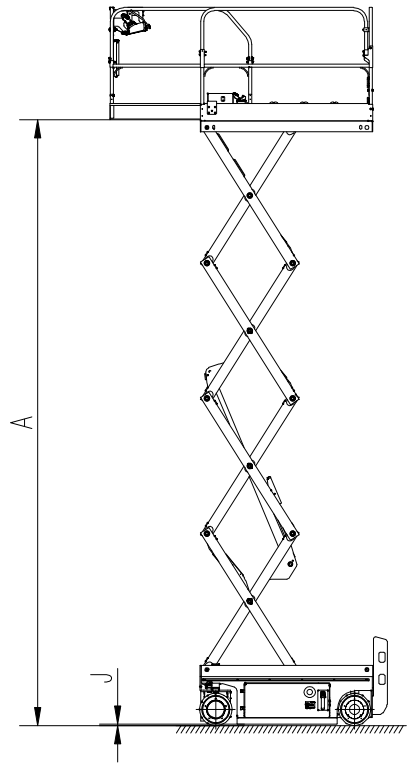

SUNWARD INTELLIGENT EQUIPMENT CO.,LTD.

Add: Sunward Industrial Park, No. 1335 Liangtang Road (E), Xingsha, Changsha, Hunan, China
E-mail:international@sunward.cc Web: <http://global.sunward.com.cn/>

